

Data sheet microchip laser MCL-1064-150-f

Fiber coupled microchip pulse laser module with emission wavelength 1064 nm
(Data sheet rev. 1.2, 2024-08-30)

Table of contents:

1 Microchip laser description.....	1
2 MCL-1064 applications.....	1
3 Microchip laser parameters.....	3
4 Control Software / Operation modes.....	5
5 Dimension and Weight.....	6
6 Included Accessories.....	6

1 Microchip laser description

The Microchip Laser module delivers short single mode pulses on demand at a wavelength of 1064 nm. The pulse repetition rate is software controlled and can be set between single shot and 500 kHz. The pulse duration is in the range of 150 ps.

The MCL-1064 contains a Q-switched microchip with pump diode and a software controlled electronic module. The microchip consist of a Nd:YVO₄ laser crystal with a saturable output coupler.

The MCL-1064 can be used

- In combination with a LabVIEW based driver for custom access via USB port
- In stand alone mode at fixed pulse rate without additional software control
- With an external clock.



2 MCL-1064 applications

Possible applications of the MCL-1064-150 can be

- Micro machining (e.g. 3D Printing)
- Light detection and ranging (LIDAR)
- Precision measurements
- Frequency conversion
- Seed laser.

3 Microchip laser parameters

Parameter (@200 kHz)	minimum	typical	maximum	unit
Laser emission wavelength(air)	1063.8	1064.0	1064.2	nm
Spectral width		13		pm
Spectral shift		13		pm/100 kHz
Pulse energy	7.5	9		nJ
output power	1.5	1.8		mW
Pulse duration	120	150	180	ps
Repetition rate	Single shot		500	kHz
Polarization	Linear to slow axis			
Pol. Ext. Ratio (PER)	20			dB
Timing jitter (σ)		1.8	3.0	ns

special parameters for synchronization to external clock/trigger

Parameter	minimum	typical	maximum	unit
Input signal	0.05		5	V
Input impedance		50		Ω
Pulse distance	2			μ s
Trigger Pulse delay (@1 kHz)*		850	1500	ns
Trigger Pulse delay jitter (σ) *		7	15	ns

* decreases for higher repetition rates

Other Features

- Fibre output: SM98-PS-U25D fibre + FC/APC connector, Fibre length 40 cm +/- 10 cm
- Stand alone mode at fixed pulse rate without software control
- A Laptop or PC with Win 7 or higher, one USB port and LabVIEW drivers is required for full operation mode

Output Power

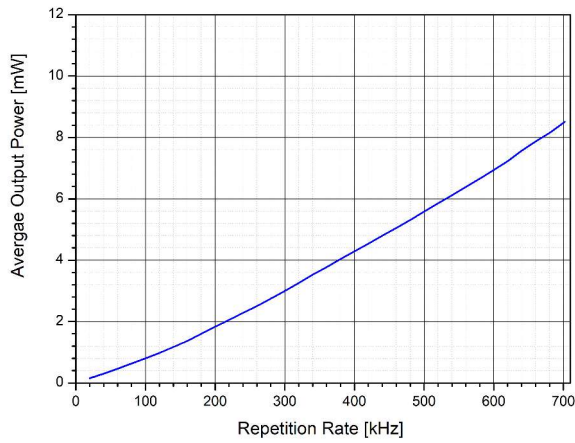

Pulse Energy

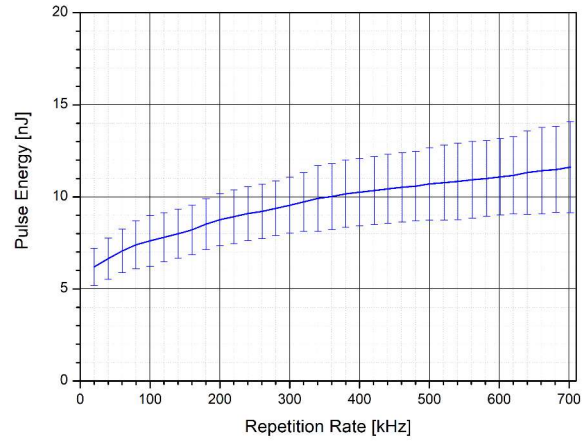

Pulse Duration

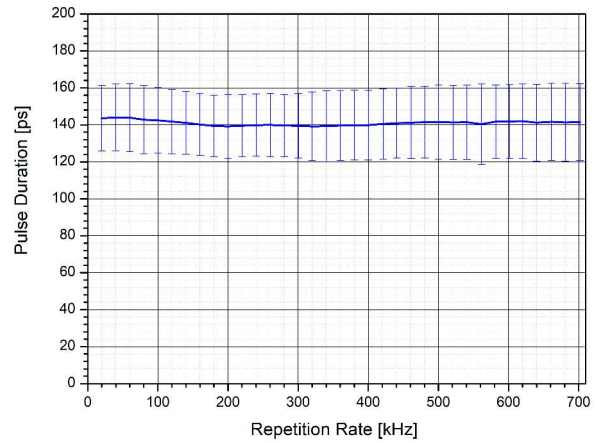
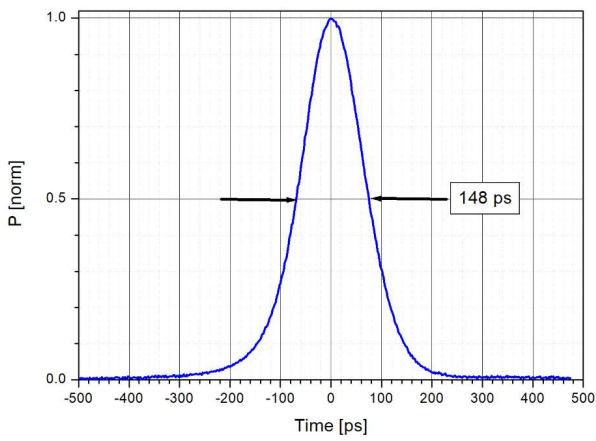

Pulse Spectrum

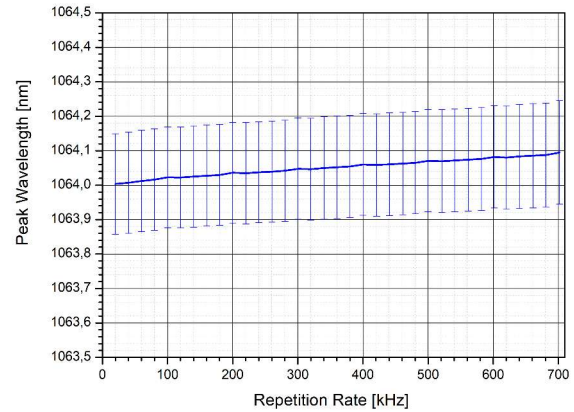
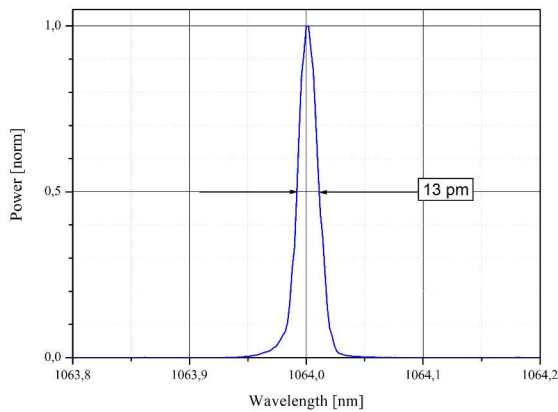

Timing Jitter Histogram

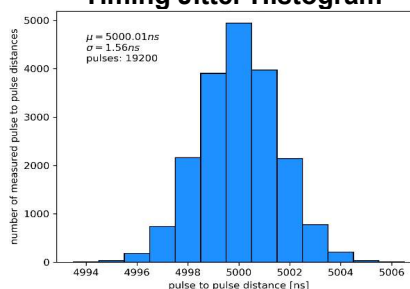

4 Control Software / Operation modes

The supplied control software includes a LabVIEW executable and console version of the control software. A LabVIEW driver to access the laser module via USB can be provided on request.

The provided control software can be used to:

- Switch the laser on or off
- Reconfigure the repetition rate of the laser
- Manage trigger modes
- Check the status of the laser

Operation modes:

- Stand alone mode:
no PC connection required, MCL-1064 works with 200 kHz internal clock (factory setup)
- Internal trigger:
controlling the MCL-1064 by software, repetition rate is set by an internal trigger source (typical 1 kHz to 500 kHz)
- External trigger:
repetition rate is set by an external trigger source (not included) using Trigger In Port (SMA)
control software is required only once to switch to external trigger mode



Executable LabVIEW software

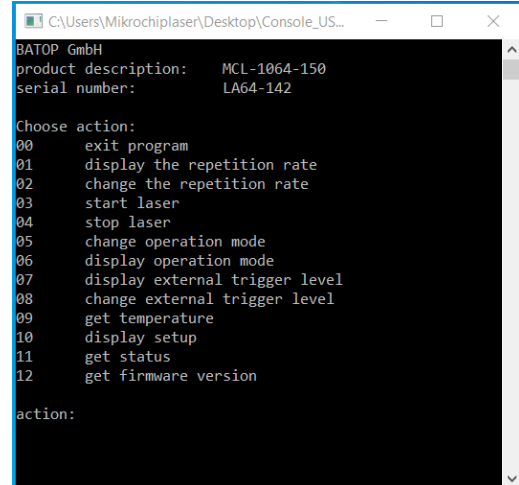

Console software

5 Dimension and Weight

Dimension:

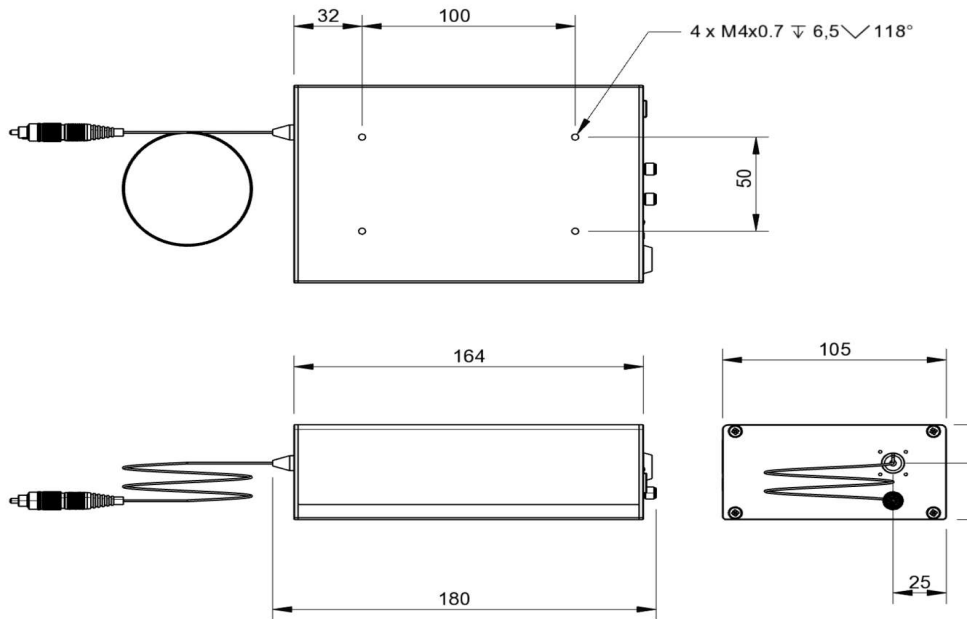

Weight: 920 g +/- 20 g (without external power supply)

6 Included Accessories

- external power supply, 110 – 230 V, output 25W
- USB-cable
- Key
- User manual
- Control software

